

Mikron

# MILL E

800  
1200



# Passion for Precision

## GF Machining Solutions

When all you need is everything, it's good to know that there is one company that you can count on to deliver complete solutions and services. From unmatched Electrical Discharge Machining (EDM), Laser texturing, Laser micromachining, Additive Manufacturing and first-class Milling and Spindles to Tooling and Automation, all of our solutions are backed by unrivaled Customer Services and expert GF Machining Solutions training. Our AgieCharmilles, Microsolution, Mikron Mill, Liechti, Step-Tec and System 3R technologies help you raise your game—and our digital business solutions for intelligent manufacturing, offering embedded expertise and optimized production processes across all industries, increase your competitive edge.

+ We are Mikron Mill.  
We are GF Machining Solutions.

# Contents

4	Applications
6	Highlights
7	Accuracy
8	Body design
9	Quality - a part of our Highlights
10	Oversized work capacity
11	Around the workpiece
14	Spindles with character
15	Automatic tool magazine
16	Chips and coolant management
17	Customer Services / Options
18	smart machine
19	Control system HEIDENHAIN
<hr/>	
20	Technical data
22	GF Machining Solutions

## **Mikron MILL E -**

### **Expand your expectations, rally behind flexibility.**

This range of vertical machining center sets standards in the VMC category. Its values are simplicity, modernity and robustness allied with a never before seen price/performance ratio.

The perfect harmonization of both machining performances and stability is the fruit of innovation efforts based on the long experience of our engineers. The result is reliable high precision production equipment with an irreproachable operation in any situation.

## Applications

# Efficient production in universal applications

### Cardan joint element

X22CrNi17

Aerospace

- + Multiside machining on a dividing head
- + High accuracy
- + Machined from the solid

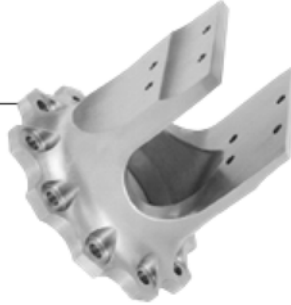

### Custom gripper

AlSi1MgMn

Machine tool industry

- + Machined from the solid
- + Thin wall structure
- + Contour de burring

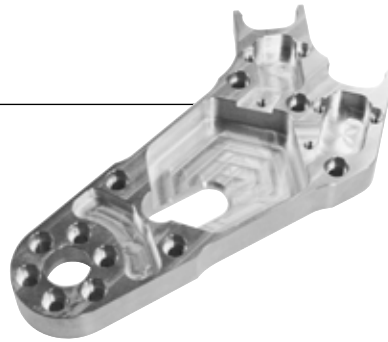

### Baseplate

AlCu4Mg1, 5

Electronic industry

- + Efficient multi-pocket milling
- + Fast positioning
- + High position accuracy
- + Milling, drilling, boring and tapping

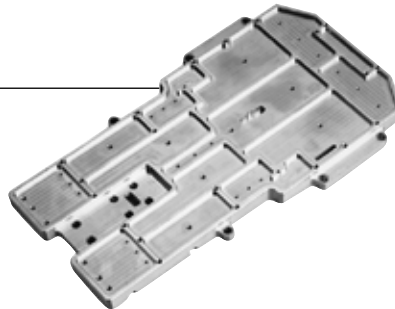

### Mold base

X153CrMoV12

Mold & Die industry

- + Efficient material removal
- + High geometry accuracy
- + Rigid tapping in steel

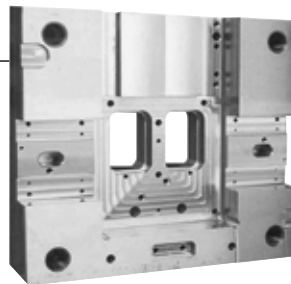

### Mold Core

10Ni3MnCuAl (NAK80)

Automotive Industry

- + Efficient material removal
- + Excellent surface quality

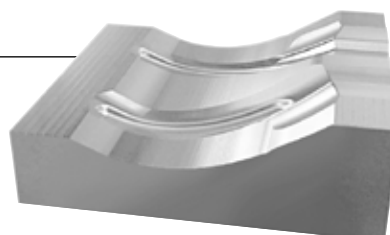



Application sample: one setup machining from the solid of a tool handling gripper.

## Highlights

# Efficiency redefined

Best cover design for ergonomic operating and part loading

Two adjustable air blow hoses and two adjustable coolant hoses

Efficient chip evacuation through smooth inner cover design

Highest path accuracy ensured by state of the art numerical control



Customizable chip and coolant management adapted to your need

Unique divided coolant tank system allowing user friendly maintenance (chip sump)

Safe machine setups thanks to a perfect all-around view to work area

### Further highlights

- + Compact construction
- + Best rigidity by high dynamic and maximum reliability
- + Almost all options can be retrofitted
- + Power drives on all axes (no vibration generating counterweight)
- + Security level according to European standards
- + High End numerical control
- + Excellent price/performance ratio

## Accuracy

# A core component

The Mikron MILL E machines fill all preconditions for handling even the very stringent accuracy requirements of the high precision parts production.

Top-performing on part accuracy requires from the machining center:

- + High geometric accuracy
- + High positioning accuracy
- + High dynamic accuracy
- + High thermal accuracy
- + High referencing accuracy

### Designed for dynamic accuracy

...“The structural stiffness and high gain position loop are both main criteria in the design of a dynamic precision machine tool“...

- + Optimized static and dynamic stiffness based on FEA analyses
- + High system reaction thanks to powerful drive algorithm
- + High contour fidelity thanks to high look ahead
- + Fast machining at specified accuracy thanks to contour path tolerance

### Machined and adjusted in lowest tolerances

The ultimate geometric accuracy of the final assembled structure is the basis for precision machining.

- + Hand scraped geometries
- + Dished clamping geometry ensures a float-free hold

### Simpler set-up with workpiece probe

#### OMP 40-2

The infrared probe set into the spindle enables efficient set-up, recognition and measurement of the workpiece (Optional). It shortens setup time considerably.

### Safe production with tool probe TS 27

Accurate tool set-up, safe broken tool monitoring - length and diameter of the tools can be measured precisely with the probe mounted on the working table (Optional).

### Lasting positioning accuracy

Linear optical encoders are the precondition for machines that must fulfill a high and lasting positioning accuracy by high machining speed.

Indirect measuring systems, also coupled to ballscrew cooling or magnetic encoders are now more efficient under such requirements.

Compensates:

- + Errors due to thermal drifts
- + Errors due to friction variations
- + Errors due to normal wear

We test positioning accuracy according to ISO 230-2 (2014).

GF Machining Solutions

Understanding precision...



### Keeping accuracy also on long machining time

A stable thermal behavior on the tool center point despite a powerful cutting performance.

- + Main heat sources isolated by coolplates
- + Liquid core cooled casting structure
- + Intelligent thermal control

## Body design

# Optimized to perfection

### Body sculptured machine frame

The machine design, optimized by means of state of the art simulation and analysis tools provide solidity throughout the machining center. The generously sized cast iron construction also stands out due to its excellent vibration absorption properties with high stability and rigidity, even under full load and in continuous operation. The result is a stable milling behavior which ensures a lasting quality of a high accuracy production process.

### Strong spindle head

The widely supported and strongly constructed spindle head enables a high-powered milling / drilling operation on the Z-axis. A closed internal coolant circuit stabilizes and controls temperature drifts of the spindle head.

### High-performance Spindles

The high-performance Spindles on the Mikron MILL E series are designed to do heavy roughing and Milling to best surface finish all at once.

With a bearing design with three preloaded hybrid ball bearings in the front and a thermally robust hybrid cylindrical roller bearing on the back, you are guaranteed a super-rigid rotating system that enables Milling with extra-long tools reaching into deep cavities. Ramp up your chip removal, thanks the feed rates made possible by his solution's absorption of high Milling forces at the tool tip.

### Perfect linear motions

Pre-stressed and double anchored ballscrews ensure the perfect linear motions - an important prerequisite for high workpiece precision.

Linear guides with high rigidity and high load capacity ensure the smoothness in all displacements. Higher machining efficiency is generated through coexistent superior geometrical accuracy and surface quality of the machined work-pieces. The high rigidity makes for better vibration behavior with diminished vibration amplitudes and thus extends tool lives. A central oil lubrication system ensures their highest durability.

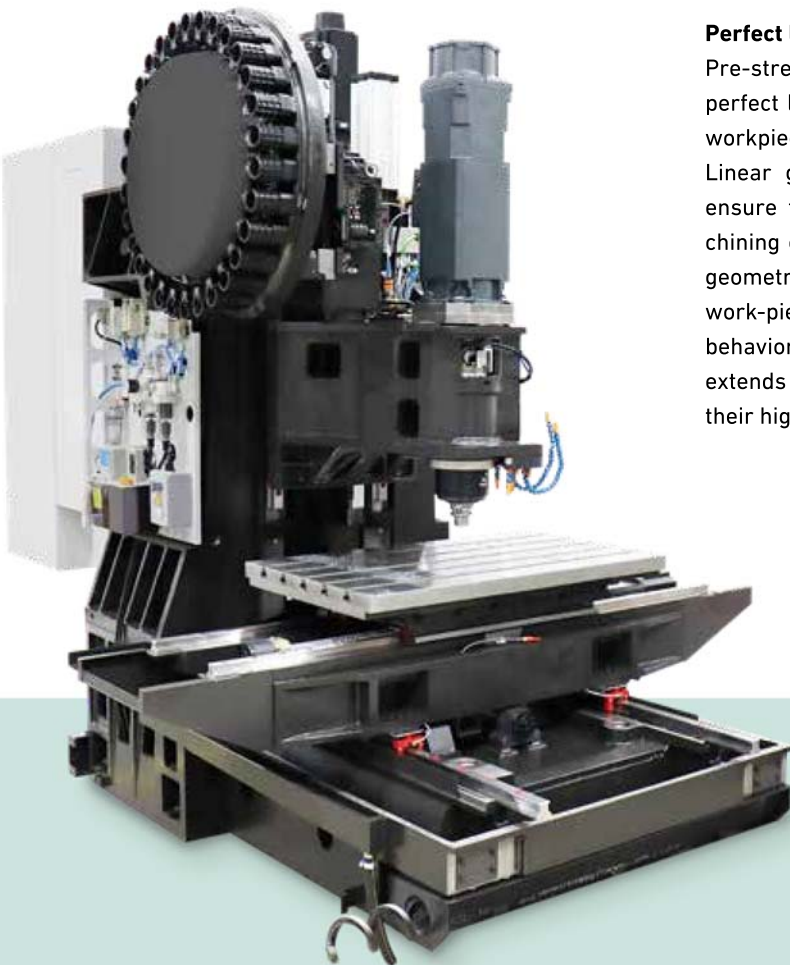



Quality - a part of our Highlights

# Efficiency and flexibility redefined

## Quality you can rely on

- + Completely designed and produced by GF Machining Solutions which has dedicated all the know-how of its engineering crew
- + As far as possible, the "carry-over" principle has been applied to maximize the component reliability
- + Structural components have been optimized using newest numerical simulation assistance to reach an ideal solution

## Quality you can afford

Conscientious cost control along the design phase led to a product that integrates the best of GF Machining Solutions technologies in a modern, reliable milling machine affordable for a large customer field.

- + Fast machining at specified accuracy
- + Workshop oriented programming at the machine
- + Conversational man-machine interface

## Swissness inside

For over 100 years, machine tools from GF Machining Solutions have proved their quality in their daily use by demanding customers.

While the machines have undergone continuous development during this period, the Swiss principles of quality care have remained the same.

- + Design determined built-in accuracy
- + Meticulous detail care
- + Consistency, Quality, Reliability

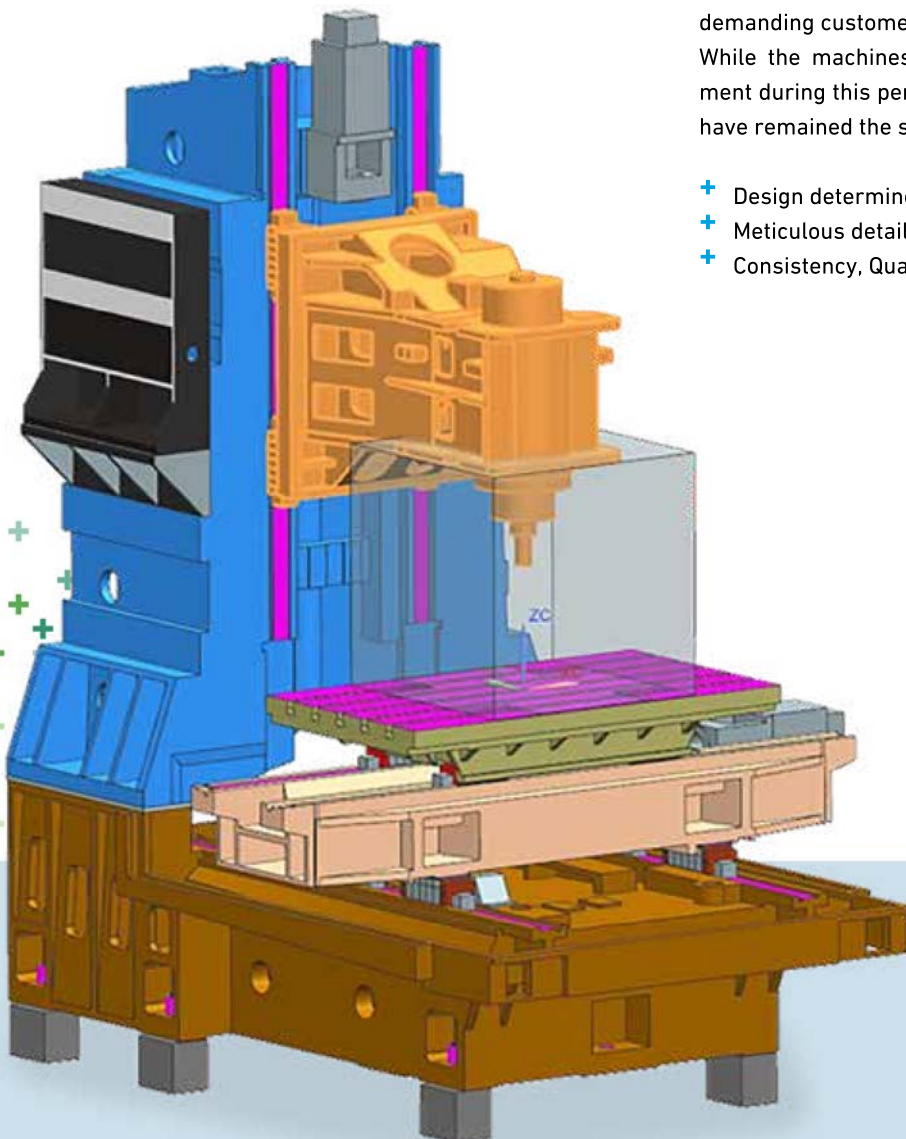

Oversized work capacity

# Roomy interior that opens new perspectives...

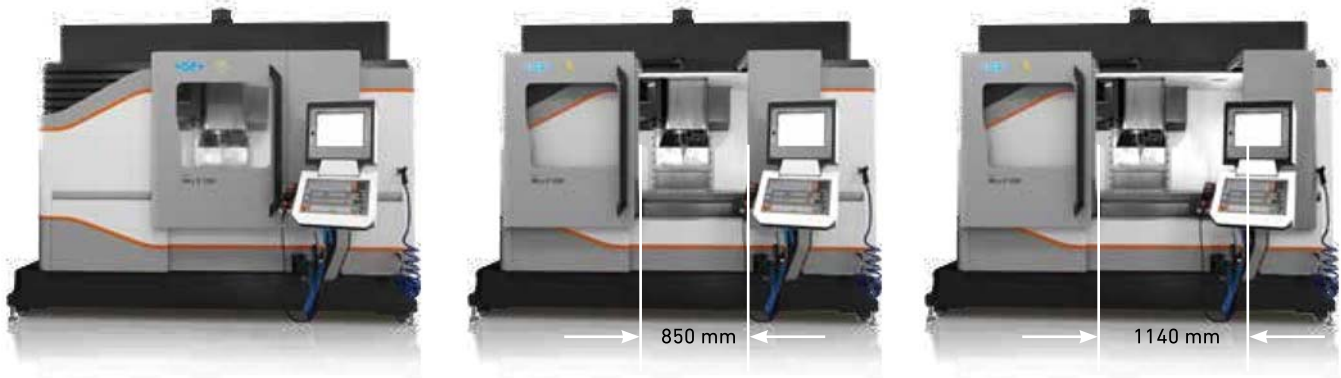

**Mikron MILL E with its two sliding doors allowing direct and ergonomic access to the working table.**

## Better access to the work area

The Mikron MILL E feature a unique "1+1/2" door principle. Safe working is guaranteed by the large screens of the smoothly sliding main door. The side panel ensures that once the door is slid open, there is an optimized access for big part loading or cleaning operations.

## Integrated compressed air connection

The table has as standard equipment an integrated air supply that can be used to supply various part clamping systems.

This feature adds flexibility to your choice of the right solution.

- + Fits pneumatically operated zero point pallet clamping systems.
- + Fits pneumatically operated part clamping systems.

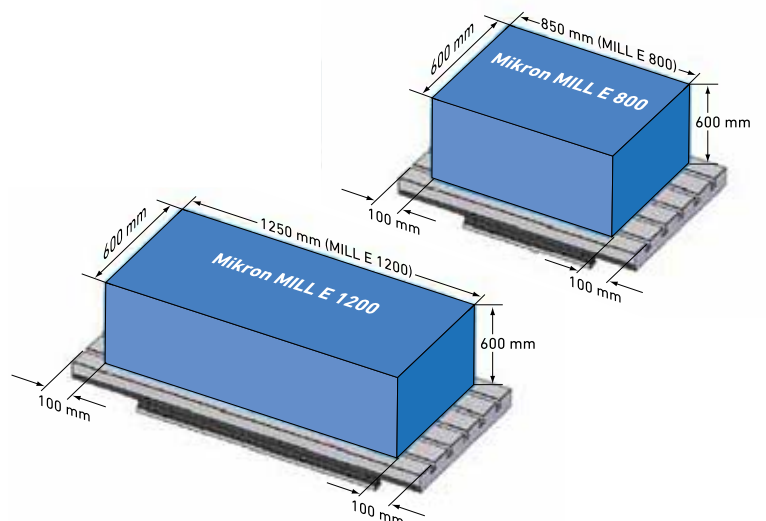

## Machining capability over the full travel

The oversized table offers enough surfaces to safely clamp workpieces that have been machined. The dimension ensures that the workpiece can always be clamped. Directly machined in the cast iron, the numerous T-slots permit all imaginable part fastenings and ensure their quick alignment to the machine movements.

Around the workpiece

# A good ergonomic working environment that enhances efficiency

## Easy crane loading for heavy workpieces

When constructing the cabin, great emphasis was laid on simple and safe crane loading, even with voluminous workpieces. The spacious machining area of every machine version is designed for efficient machining of large and unwieldy parts.



## More confidence in what you are doing

Be faster on frequent part setups or program run-in without risks of collision damage.

- + Full 3 sided view
- + Big sized windows
- + Bright illumination of the work area

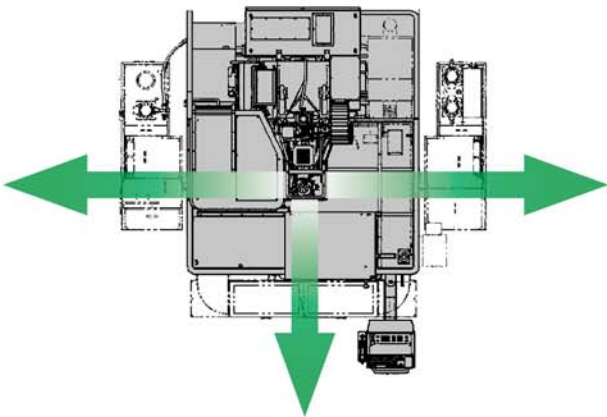

Maintenance of the large coolant tanks is facilitated, since each tank can be rolled out separately.

Standard hand wash and air pistols support the cleaning of parts or machine elements.

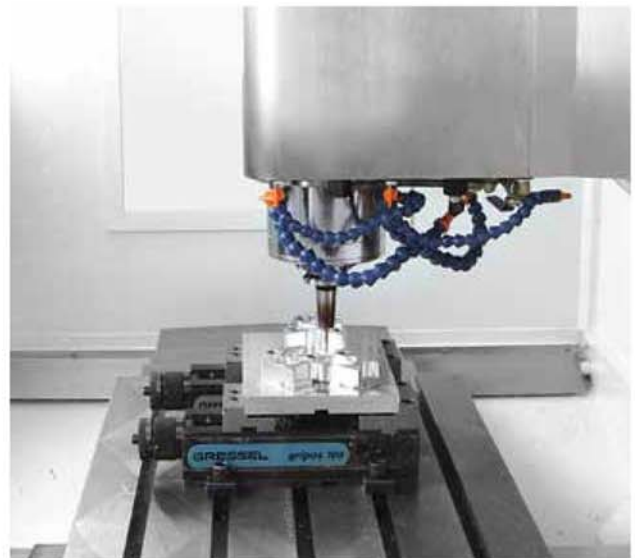

The outstanding feature of Mikron machining centers is their exceptional ergonomics. What is impressive about the concept is its unrivalled accessibility, which is not dependent on the machine's configuration.



**Mikron MILL E -  
Expand your expectations,  
rally behind flexibility.**



## Spindles with character

# A choice of three different spindles is available to meet distinctive application needs

### 12,000 rpm, ISO/BT 40

The inline spindle delivers ample performance and power for all kinds of applications. The ball bearings, which are lubricated for life, are effectively protected against incoming dirt with an air purge system.

### 16,000 rpm, HSK-A63 / ISO/BT 40

The inline motor spindle with high torque and high dynamic supports customers who are looking for speed and power in once.

Thanks to the direct coupling the spindle isolates noise and vibrations from the Z slide.

Big size barring supports the efficient milling and rigid cutting. Thanks to the vector driven spindle construction this Spindle delivers a high torque even at lower speed.

### 20,000 rpm, HSK-A63

The cartridge type Step-Tec motor spindle is flange mounted directly into the Z axis slide to minimize thermal distortion and provide ease of maintenance. The spindle taper accepts tool holders to HSK-A63 standard with retention by a hydro-mechanical system. During tool changing the taper cleanliness is maintained by a continual air blast.

Spindle life is enhanced by large oil/air lubricated hybrid ceramic bearings. The complete spindle is temperature controlled by a controlled spindle refrigerating unit over a closed loop water cooling system. This cooling unit has a large refrigerating capacity and thus allows the machine to be kept constantly refrigerated even in fluctuating temperature environments.

The controlled spindle refrigerating unit is placed by the side of the machine. The tool is cooled by 4 coolant nozzles outside of the spindle.



#### Inline type driven spindle

Spindles are the heart of the milling process. They principally determine the cutting performance of the machining center. Its location has always made it subject to damage.

- + Fits high power and torque
- + Low maintenance requirements
- + Low replacement costs
- + Compensated thermal drifts

#### Quiet and smooth at high speed

Helical Offset Tooth design merges both belt and sprocket in the quietest, smoothest and most compact synchronous drive package available.

- + Lower noise
- + Less vibration
- + Narrower drive
- + Energy saving
- + Technical strength

#### Automatic lubrication

The uninterrupted machining at maximum rotation speed is possible on the 16k spindle thanks to the automatic regreasing capability.

- + Long-term lubrication
- + Low lubricant consumption
- + Cost savings
- + Reduced maintenance

Automatic tool magazin

# Faster and uninterrupted production

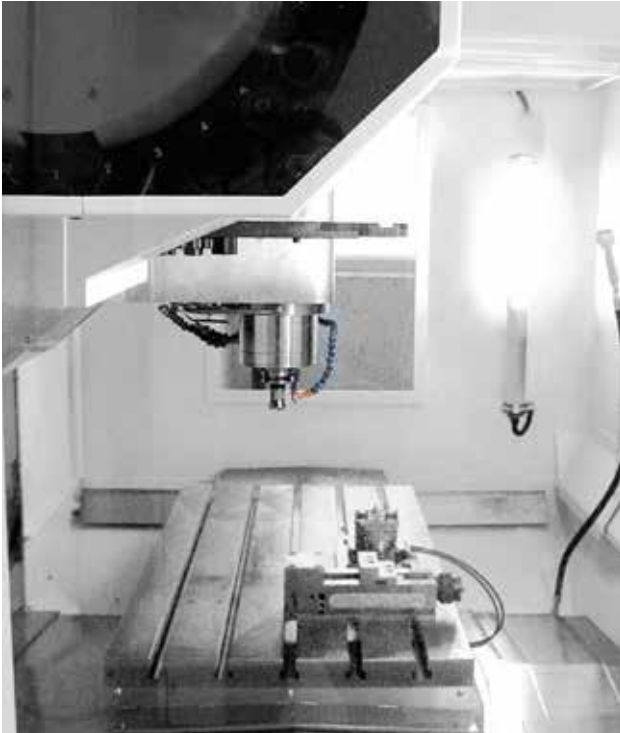

## Safe and reliable working

All tools are optimally protected from chip contamination since the tool changer is separated from the working area.

- + Contamination protected tool storage
- + Checking window enhances operation safety

## Minimized non productive times

Because every human intervention within the machining process is a potential error source and wastes time.

- + Side-mounted automatic tool changer
- + High capacity storage
- + Fast gear cam driven double arm gripper system

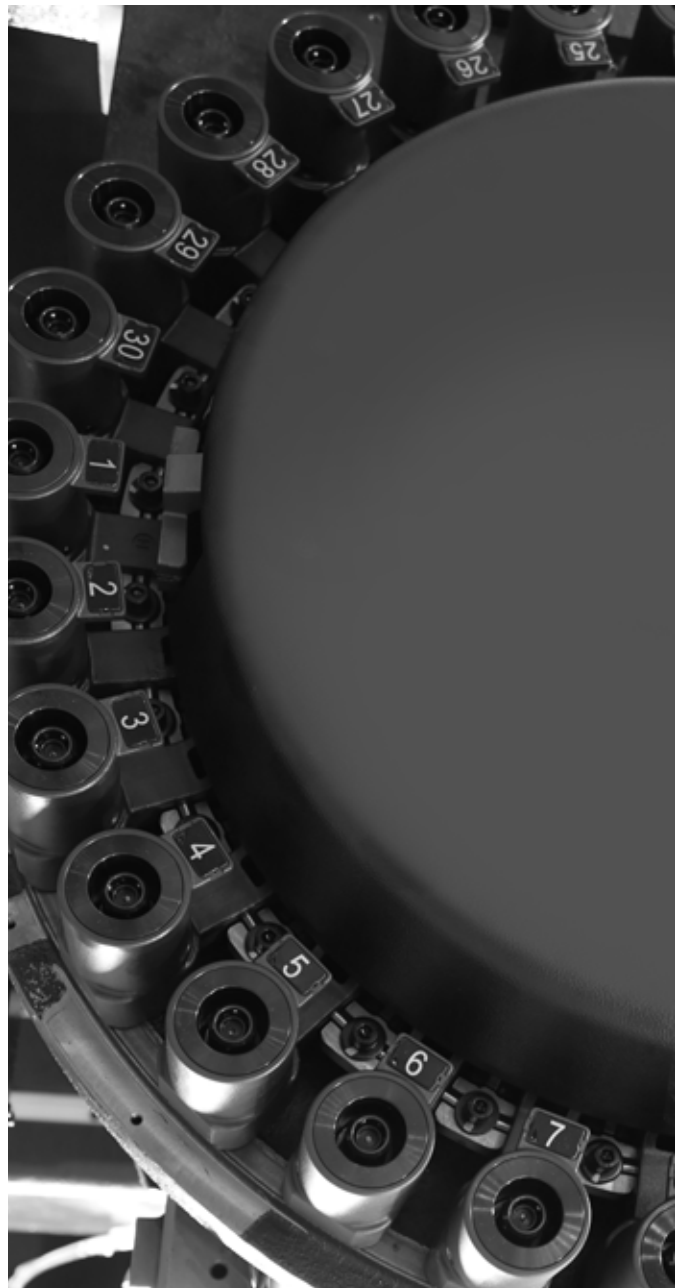

## Chips and coolant management

# Clean and easy

### The triple benefits of high flow flushing

- + Ensures good lubrication of the cutting edge.
- + Prevents premature tool wear and reduces the local heat transfer which enhances the machining accuracy.
- + Avoids chip accumulation around the cutting process and facilitates their evacuation.

Always guaranteed by:

- + 6 adjustable high flow coolant nozzles
- + 2 adjustable air blow off nozzles

### Cooling from all directions

The integrated nozzles located around the spindle eliminate any difficulties in adjusting single cooling jets on complex part geometries.

### Cooling through the spindle, 20 or 50 bar

The coolant is guided under high pressure through the work spindle directly to the cutting edges. The advantages are higher cutting speeds, problem-free peck drilling, blind hole milling and extended service life of tools.

### Smooth inner cover design

Great attention has been paid to the flow of chips in the working area.

Sharply inclined side walls optionally combined with flushing systems direct chips straight to the evacuation channels.

The chips are then efficiently transported out of the work area by chip conveyors.



Standard hand wash and air pistols support the cleaning of parts or machine elements.



## Customer Services

# New digital service possibilities

GF Machining Solutions Customer Services continues to push technological boundaries to deliver the future of services to you—today.

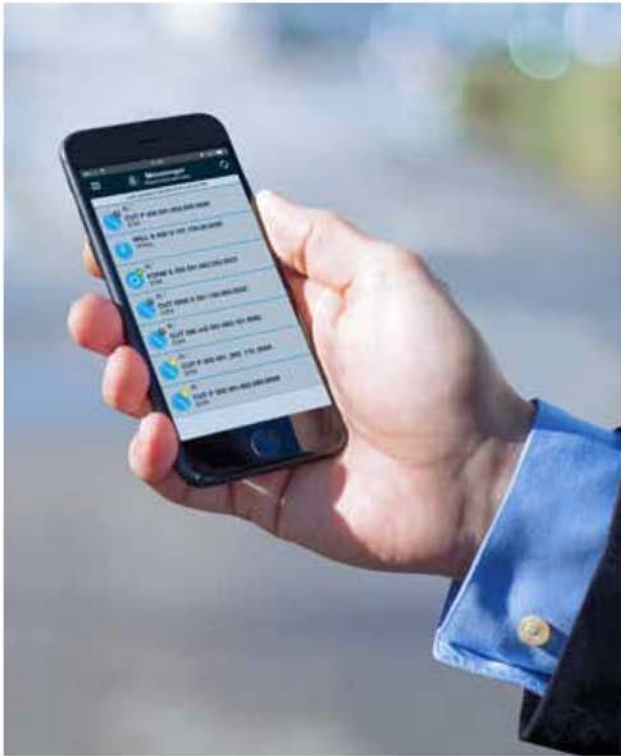

**rConnect** is the digital services platform available for all GF Machining Solutions technologies. Following a modular approach, rConnect comprises a range of services that empower you to increase your manufacturing productivity. Certified with the TÜViT Trusted Product Certificate.

**rConnect Messenger**, we deliver machine data to your mobile device to keep you constantly informed about your production. You can supervise your workshop from your smartphone.

**rConnect Live Remote Assistance (LRA)**, our expert engineers rapidly respond to your service requests. LRA allows effective face-to-face assistance using audio, video, chat and many more functionalities.



## Options



Front conveyor

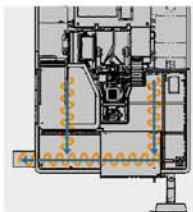

Front and side conveyor



TSC 20 or 50 bar supply unit



Mist extraction unit

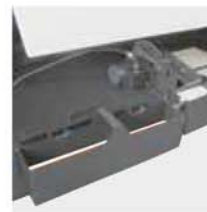

Mechanical oil/coolant separator



Beacon



Glass scales



OMP 40-2 touch probe



TS 27 table touch system



Laser tool measuring system



Tool magazine CT 60



Lift-up chip conveyor system

## smart machine

# Enhance your process beyond program and machine setup

This includes a range of modules collectively referred to under the generic term “smart machine” and that fulfill various functions. In order to make the Milling process “intelligent,” various requirements have to be implemented.

**1<sup>st</sup>** is establishing comprehensive communication between man and machine, which makes available precise information that the operator requires to assess the Milling process.

**2<sup>nd</sup>** is supporting the operator in the optimization of the process, which considerably improves the performance.

**3<sup>rd</sup>** is the machine optimizing the Milling process, which improves process safety and workpiece quality—especially important in unmanned operation.

### The facts

- + Greater accuracy in shorter machining times
- + Increase in the workpiece surface quality as well as the surface and shape accuracy
- + Recognition of critical machining strategies
- + Improved process safety
- + Higher availability
- + Better operating comfort
- + Considerable increase in reliability in unmanned operation

- + Produce your workpieces in a process-secure and precise manner.
- + Increase reliability in unmanned operation.
- + Boost the service life of the machine.
- + Significantly reduce production costs.

### smart machine construction kit system

Each of the modules fulfills a specific task. Just like in a construction kit, the user can select the modules that seem to him to be the best option for improving his process.

#### Time

smart machine modules like OSS and software tools such as rConnect boost your productivity.

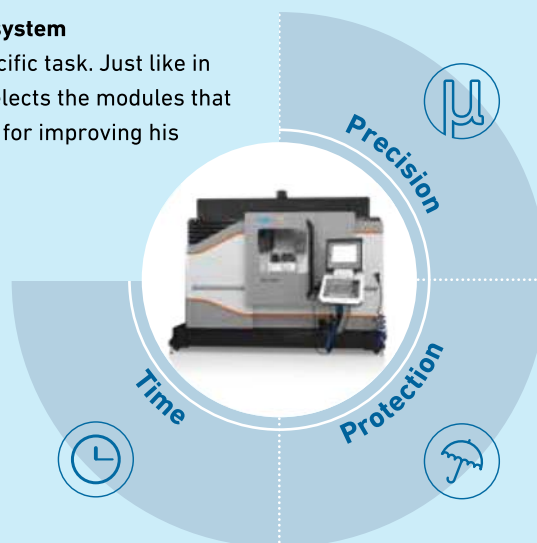

#### Precision

smart machine modules like ITC, OSS and ISM/ISM extended support the precise base of your machining center to achieve an even more precise final part.

#### Protection

smart machine modules like PFP protect and extend the lifetime of your machine and tools.

Control system HEIDENHAIN

# TNC 620 offers quick and reliable Machining with High Contour Fidelity

Heidenhain's Touch Numerical Control, the TNC made its mark in the demanding tool and moldmaking industry.

It is recognized by experts as the numerical control offering best performances and programming comfort.

The newest model, the TNC 620 once again merits this reputation.

## User friendly human interface

The 15-inch TFT color monitor shows a clear overview based on graphic supports in any situation

- + Safer programming: each traverse command is drawn on the screen
- + Faster programming: each cycle parameter is graphically illustrated
- + Fast data transfer from programming stations.

## Quick programming and part setups

TNC 620 features application-oriented setup functions that help to reduce non-productive time.

- + Straightforward function keys for complex contours
- + Field-proven cycles for recurring operations
- + Re- using of programmed contour elements
- + Workpiece presetting
- + Workpiece misalignment compensation
- + Easy machining under handwheel control



## Technical data



<b>Working Range</b>			<b>Mikron MILL E 800</b>	<b>Mikron MILL E 1200</b>
Longitudinal	X	mm	850	1250
Transverse	Y	mm	600	600
Vertical	Z	mm	600	600
<b>Table</b>				
Table size		mm	1050 x 600	1450 x 600
Max. weight on table		kg	800	1200
Distance table - spindle		mm	150 - 750	150 - 750
<b>Feed drives</b>				
Feed	X, Y, Z	m/min <sup>-1</sup>	15	15
Rapid speed	X, Y / Z	m/min <sup>-1</sup>	40 / 35	40 / 35
<b>Spindle 100% ED, S1</b>				
12'000 rpm, ISO/BT 40	(S6)	kW / Nm	11.8/89	11.8/89
16'000 rpm, HSK-A 63 / ISO/BT 40	(S6)	kW / Nm	19.5/88.5	19.5/88.5
20'000 rpm, HSK-A 63	(S6)	kW / Nm	26/91	26/91
<b>Tool magazine</b>				
DT 30	BT 40 / HSK-63	pce.	30	30
CT 60	BT 40 / HSK-63	pce.	60	60
Max. tool length		mm	300	300
Max. tool diameter		mm	80 / (125)	80 / (125)
Max. tool weight		kg	8	8
<b>Control</b>				
Heidenhain			TNC 620	TNC 620
<b>Machine weight</b>				
		kg	7000	7700
<b>smart machine</b>				
	Heidenhain		ITC, ISM, ISM extended, OSS, PFP	ITC, ISM, ISM extended, OSS, PFP
			ISM/ISM extended option only with 20K Spindle	

**Mikron MILL E 800**

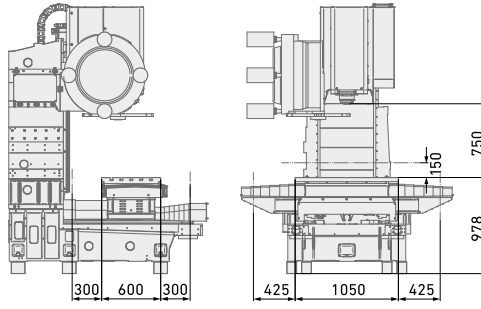
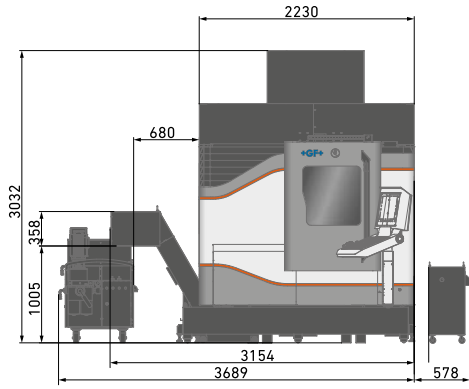

**DT 30**

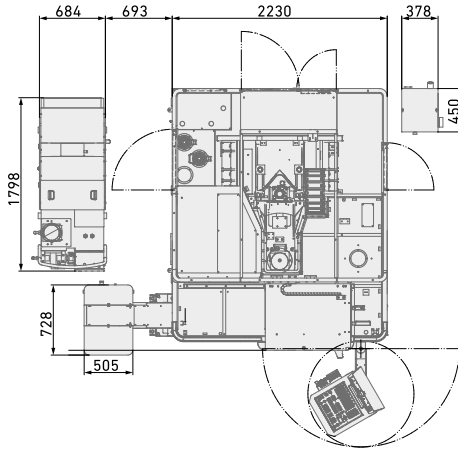

**CT 60**

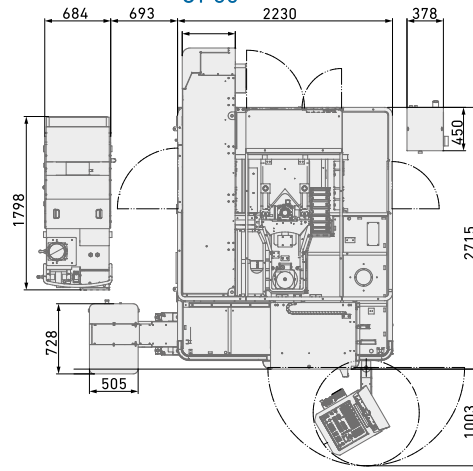

**Mikron MILL E 1200**

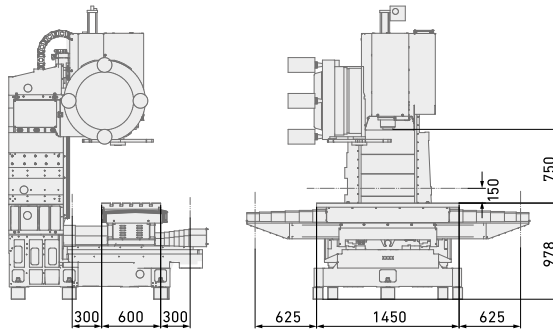
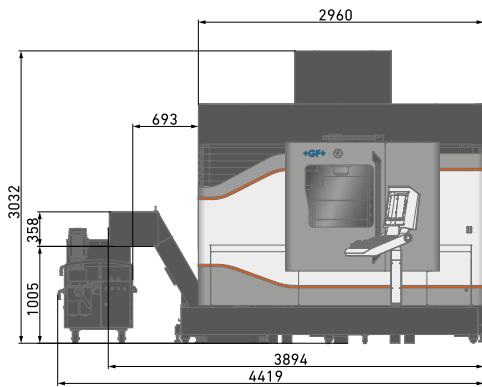

**DT 30**

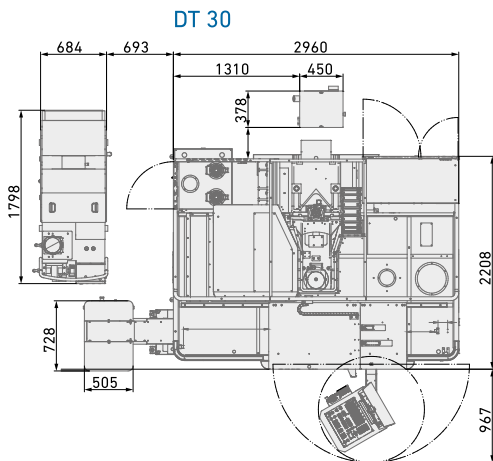

**CT 60**

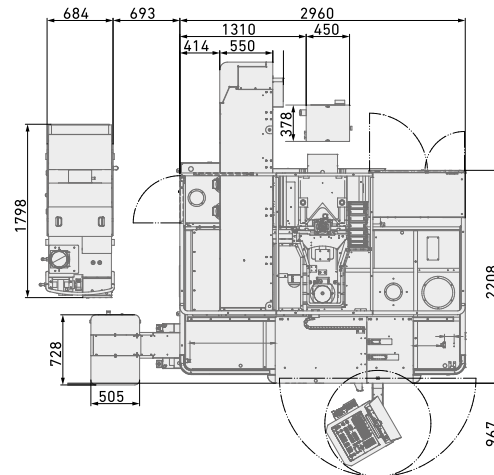

## About GF Machining Solutions

# Multi-technology solutions provider

Our commitment to you and your specific applications is proven by the value-adding intelligence, productivity and quality delivered by our multi-technology solutions. Your success is our chief motivator. That's why we are continuously advancing our legendary technical expertise. Wherever you are, whatever your market segment and whatever the size of your operation, we have the complete solutions and the customer-centric commitment to accelerate your success—today.

### EDM (electrical discharge machining)



#### Wire-cutting EDM

GF Machining Solutions' wire-cutting EDM is fast, precise and increasingly energy efficient. From ultraprecise machining of miniaturized components down to 0.02 mm to powerful solutions for demanding high-speed machining with respect to surface accuracy, our wire EDM solutions position you for success.

#### Die-sinking EDM

GF Machining Solutions is revolutionizing die-sinking EDM with features like iGAP technology to dramatically boost machining speed and reduce electrode wear. All of our die-sinking systems offer fast removal and deliver mirror finishes of Ra 0.1 µm (4 µin).

#### Hole-drilling EDM

GF Machining Solutions' robust hole-drilling EDM solutions enable you to drill holes in electrically conductive materials at a very high speed—and, with a five-axis configuration, at any angle on a workpiece with an inclined surface.

### Tooling and Automation



#### Tooling

Our customers experience complete autonomy while maintaining extreme accuracy, thanks to our highly accurate System 3R reference systems for holding and positioning electrodes and work pieces. All types of machines can easily be linked, which reduces set-up times and enables a seamless transfer of workpieces between different operations.

#### Automation

Together with System 3R, we also provide scalable and cost-effective Automation solutions for simple, single machine cells or complex, multi-process cells, tailored to your needs.

### Milling



#### Milling

Precision tool and mold manufacturers enjoy a competitive edge with our Mikron MILL S solutions' fast and precise machining. The Mikron MILL P machines achieve above-average productivity thanks to their high performance and Automation. Customers seeking fastest return on investment benefit from the affordable efficiency of our MILL E solutions.

#### High Performance Airfoil Machining

Our Liechti turnkey solutions enable the highly dynamic manufacturing of precision airfoils. Thanks to their unique performance and our expertise in airfoil machining, you increase productivity by producing at the lowest cost per part.

#### Spindles

As part of GF Machining Solutions, Step-Tec is engaged in the very first stage of each machining center development project. Compact design combined with excellent thermal and geometric repeatability ensure the perfect integration of this core component into the machine tool.

### Software



#### Digitalization solutions

To drive its digital transformation, GF Machining Solutions acquired symmedia GmbH, a company specialized in software for machine connectivity. Together, we offer a complete range of Industry 4.0 solutions across all industries. The future requires the ability to adapt quickly to continual digital processes. Our intelligent manufacturing offers embedded expertise, optimized production processes, and workshop Automation: solutions for smart and connected machines.

### Advanced manufacturing



#### Laser texturing

Aesthetic and functional texturing is easy and infinitely repeatable with our digitized Laser technology. Even complex 3D geometries, including precision parts, are textured, engraved, microstructured, marked and labeled.

#### Laser micromachining

GF Machining Solutions offers the industry's most complete line of Laser micromachining platforms optimized for small, high-precision features to meet the increasing need for smaller, smarter parts to support today's leading-edge products.

#### Laser Additive Manufacturing (AM)

GF Machining Solutions and 3D Systems, a leading global provider of additive manufacturing solutions and the pioneer of 3D printing, have partnered to introduce new metal 3D printing solutions that enable manufacturers to produce complex metal parts more efficiently.

### Customer Services



#### Worldwide for you

Ensuring the best performance throughout the lifetime of our customers' equipment is the goal of our three levels of support. Operations Support offers the complete range of original wear parts and certified consumables. Machine Support includes spare parts, technical support, and a range of preventive services to maximize machine uptime. Business Support offers customer-specific business solutions.



## Switzerland

---

Biel/Bienne  
Losone  
Geneva  
Flawil  
Langnau

[www.gfms.com](http://www.gfms.com)  
[www.gfms.com/ch](http://www.gfms.com/ch)

## Europe

---

Germany, Schorndorf  
[www.gfms.com/de](http://www.gfms.com/de)

United Kingdom, Coventry  
[www.gfms.com/uk](http://www.gfms.com/uk)

Italy, Agrate Brianza - MI  
[www.gfms.com/it](http://www.gfms.com/it)

Spain, Sant Boi de Llobregat  
Barcelona  
[www.gfms.com/es](http://www.gfms.com/es)

France, Palaiseau  
[www.gfms.com/fr](http://www.gfms.com/fr)

Poland, Raszyn / Warsaw  
[www.gfms.com/pl](http://www.gfms.com/pl)

Czech Republic, Brno  
[www.gfms.com/cz](http://www.gfms.com/cz)

Sweden, Vällingby  
[www.gfms.com/system3r](http://www.gfms.com/system3r)

Turkey, Istanbul  
[www.gfms.com/tr](http://www.gfms.com/tr)

## Americas

---

USA  
Lincolnshire, IL  
Chicago, IL  
Holliston, MA  
Huntersville, NC  
Irvine, CA  
Woodridge, IL  
[www.gfms.com/us](http://www.gfms.com/us)

Canada, Mississauga ON  
[www.gfms.com/us](http://www.gfms.com/us)

Mexico, Monterrey NL  
[www.gfms.com/us](http://www.gfms.com/us)

Brazil, São Paulo  
[www.gfms.com/br](http://www.gfms.com/br)

## Asia

---

China  
Beijing, Shanghai, Chengdu, Dongguan,  
Hongkong, Changzhou  
[www.gfms.com/cn](http://www.gfms.com/cn)

India, Bangalore  
[www.gfms.com/sg](http://www.gfms.com/sg)

Japan  
Tokyo, Yokohama  
[www.gfms.com/jp](http://www.gfms.com/jp)

Korea, Seoul  
[www.gfms.com/kr](http://www.gfms.com/kr)

Malaysia, Petaling Jaya  
[www.gfms.com/sg](http://www.gfms.com/sg)

Singapore, Singapore  
[www.gfms.com/sg](http://www.gfms.com/sg)

Taiwan  
Taipei, Taichung  
[www.gfms.com/tr](http://www.gfms.com/tr)

Vietnam, Hanoi  
[www.gfms.com/sg](http://www.gfms.com/sg)

## At a glance

We enable our customers to run their businesses efficiently and effectively by offering innovative Milling, EDM, Laser, Additive Manufacturing, Spindle, Tooling and Automation solutions. A comprehensive package of Customer Services completes our proposition.

[www.gfms.com](http://www.gfms.com)

